

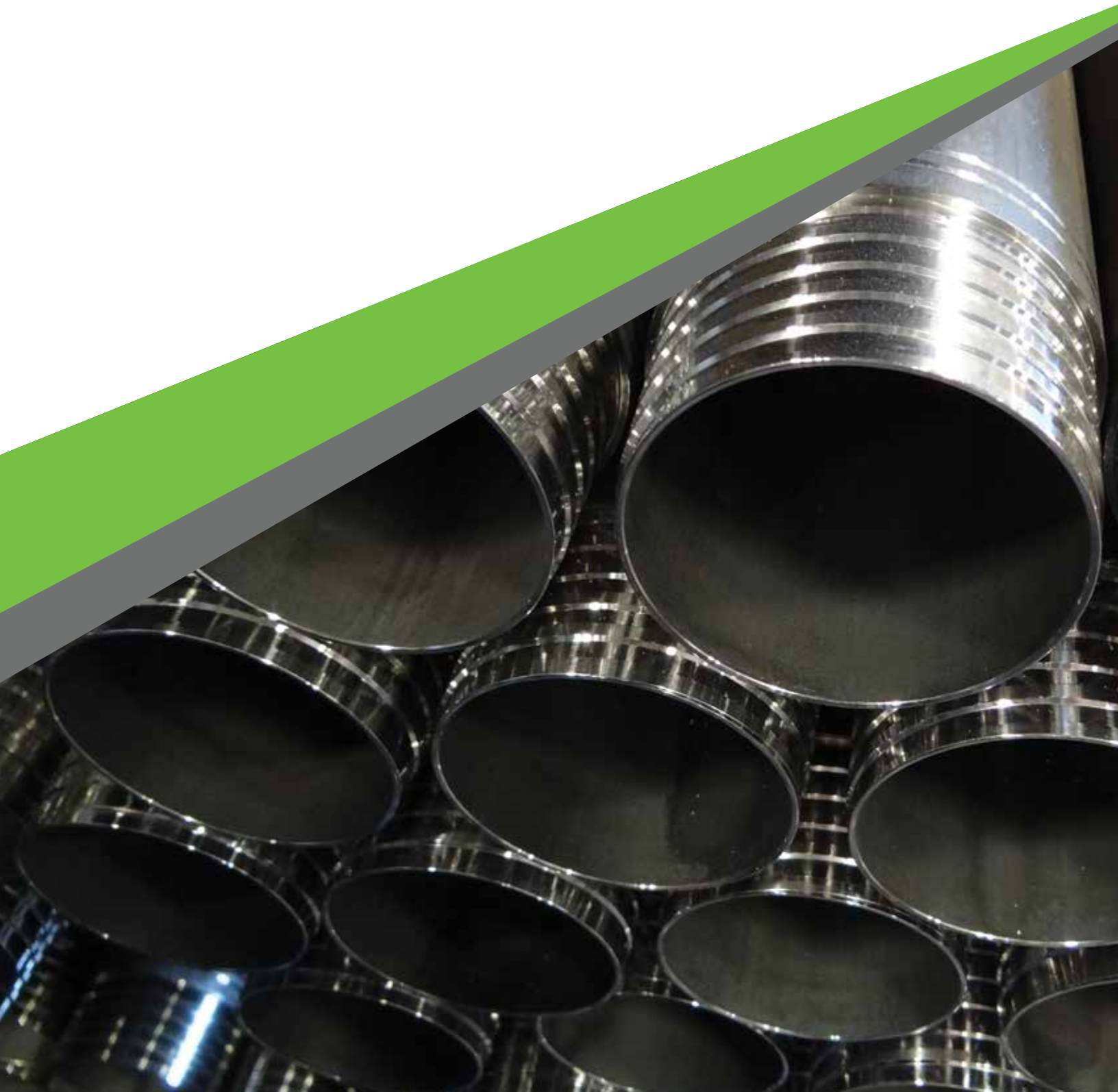

WIRELINER CORING RODS



THE DI-CORP QUALITY DIFFERENCE

When it comes to drill rods, reliability is key. No one wants to waste time and precious budget fishing for a broken rod string and lost tooling. More reliable drill rods mean cleaner shifts, reduced downtime, and increased productivity, resulting in improved profitability for drillers.

That's where Drillers Edge coring rods shine. Our rods have earned a global reputation for outstanding reliability, achieving up to two times the normal drill string life compared to major competitors under the same conditions.

Our outstanding performance in the field starts with extremely high standards at every stage of manufacturing. We begin with the highest quality steel and steel alloy tubing that meets our demanding specifications for concentricity. Then we use our proprietary approach to heat treating to virtually eliminate internal mechanical stress within the rod, making it more resilient to downhole forces.

After precision machining, our threads undergo a specialty surface treatment process that reduces galling. The combined result leads to longer drill

string life, reduced wear on both pin and box threads, and less bulging, belling, and breaking. Our dedication to quality extends throughout the process with:

- Gauging every rod, box, and pin thread before shipping out.
- Regular fit testing of finished rods throughout each day – checking for galling, damaged/malformed threads, and consistency in stand-off.
- Frequent systematic inspections to ensure they meet specs – any rods that fail inspection are discarded and production processes are adjusted as required.
- Environmentally friendly factory coating of box and pin ends to reduce friction for less torque on make-up and reduced galling.
- Biodegradable plastic caps protect threads from damage and prevent the compound from becoming contaminated or removed in shipping.
- All rods are coded for tracking and quality follow-ups.

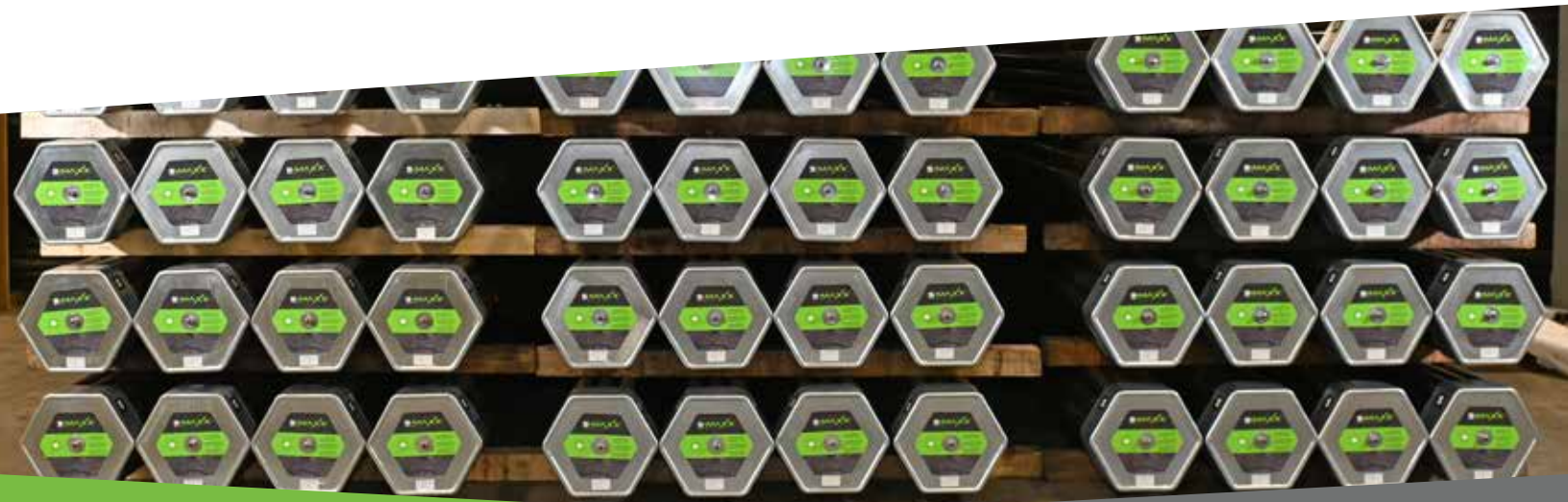

DRILL ROD TUBING OPTIONS

If depth capacity and/or drill string weight becomes an issue, Drillers Edge offers a lighter-weight drill rod alternative in S-Maxx, deep hole (D), reverse flank (R), and standard wireline (WL) thread forms.

The variable wall thickness ensures a strong joint while decreasing the overall weight of the drill rod without compromising life while parallel wall tubing offers a more robust rod.

PARALLEL WALL TUBING

Uniform wall thickness for even wear and less vibration resulting in longer life.

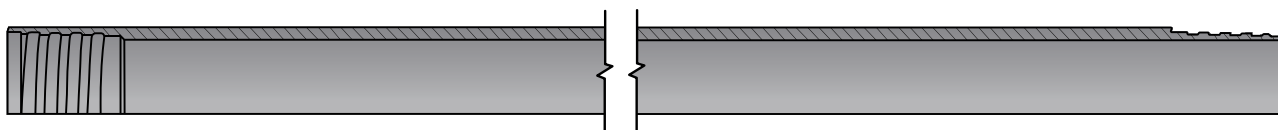

VARIABLE WALL (LITE) TUBING

The Variable Wall (LITE) tubing option offers an internally upset midbody, resulting in less rod weight for greater deep hole drilling with smaller, lower-powered drills.

- Weight reduction: N = 12% | H = 22% | P = 23%
- Easier and less expensive mobilization to site.
- Thinner midbody makes LITE drill rods ideal for projects requiring wedging.

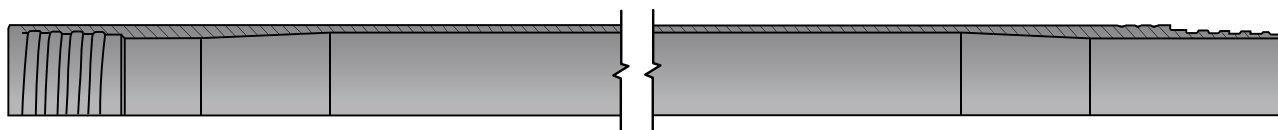

SPECIALTY DRILLING RODS

We also offer specialty drill rods in BRTK, NTW, and HTW options. Contact a sales representative for more details.

DRILL ROD THREAD OPTIONS

Di-Corp offers four different thread profiles to best meet the needs of your drilling conditions: the S-Maxx™ dual start thread, standard wireline (WL), Deep Hole (D Thread), and the Reverse Flank (R™).

S-MAXX™ WIRELINE DRILL ROD

Next generation drill rods specifically designed to withstand greater pressure, reach greater depths, and achieve maximum drilling efficiency. The dual start S thread delivers more surface area and contact, resulting in faster make and breaks and the highest torsional and tensile strength in the market.

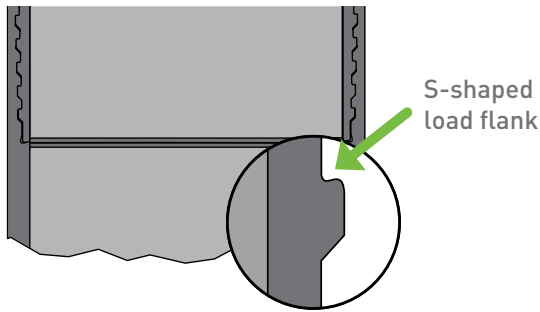

DEEP HOLE “D” THREAD WIRELINE DRILL ROD

Our patented “D” Thread drill rods transfer force more efficiently than standard wireline for less chance of joint failure (slipping and/or popping), making them well-suited for deeper holes.

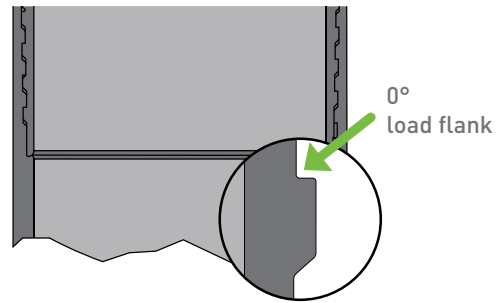

STANDARD WIRELINE “WL” DRILL ROD

Industry-standard thread form that’s been used in the field for decades.

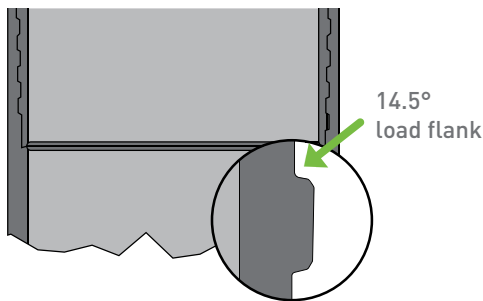

R™ REVERSE FLANK WIRELINE DRILL ROD

Our version of the reverse flank thread form, engineered to precise tolerances for more strength.

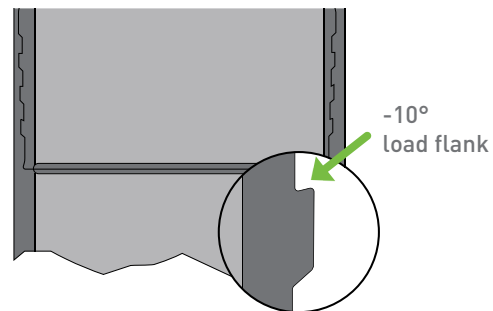

DI-CORP'S UNIQUE INDICATOR GROOVES

Each rod is engraved with our unique indicator grooves to help drillers easily identify the thread in use and its joint location to help improve productivity and safety. By providing easy identification of the thread with an exterior indicator, our drill rods:

- Help prevent accidental mixing and matching of equipment in the field, thereby avoiding unsecured drill string components.
- Save time when tripping the drill string by easily identifying joints.
- Provide an easy visual wear indicator of the outside diameter.



Di-Corp drill rods come with engraved indicator grooves on the outside of the rod to quickly identify the thread. One groove for R thread, two grooves for D thread, three grooves for S-Maxx (pictured), and no grooves for standard wireline.

WARNING: All threads are precision machined and mixing Di-Corp rods with other manufacturers' rods, adaptors, or threaded accessories is not recommended. Failure to adhere to this recommendation may cause premature failure, an investigation may result in the warranty becoming void.



DRILL ROD DEPTH CAPACITY

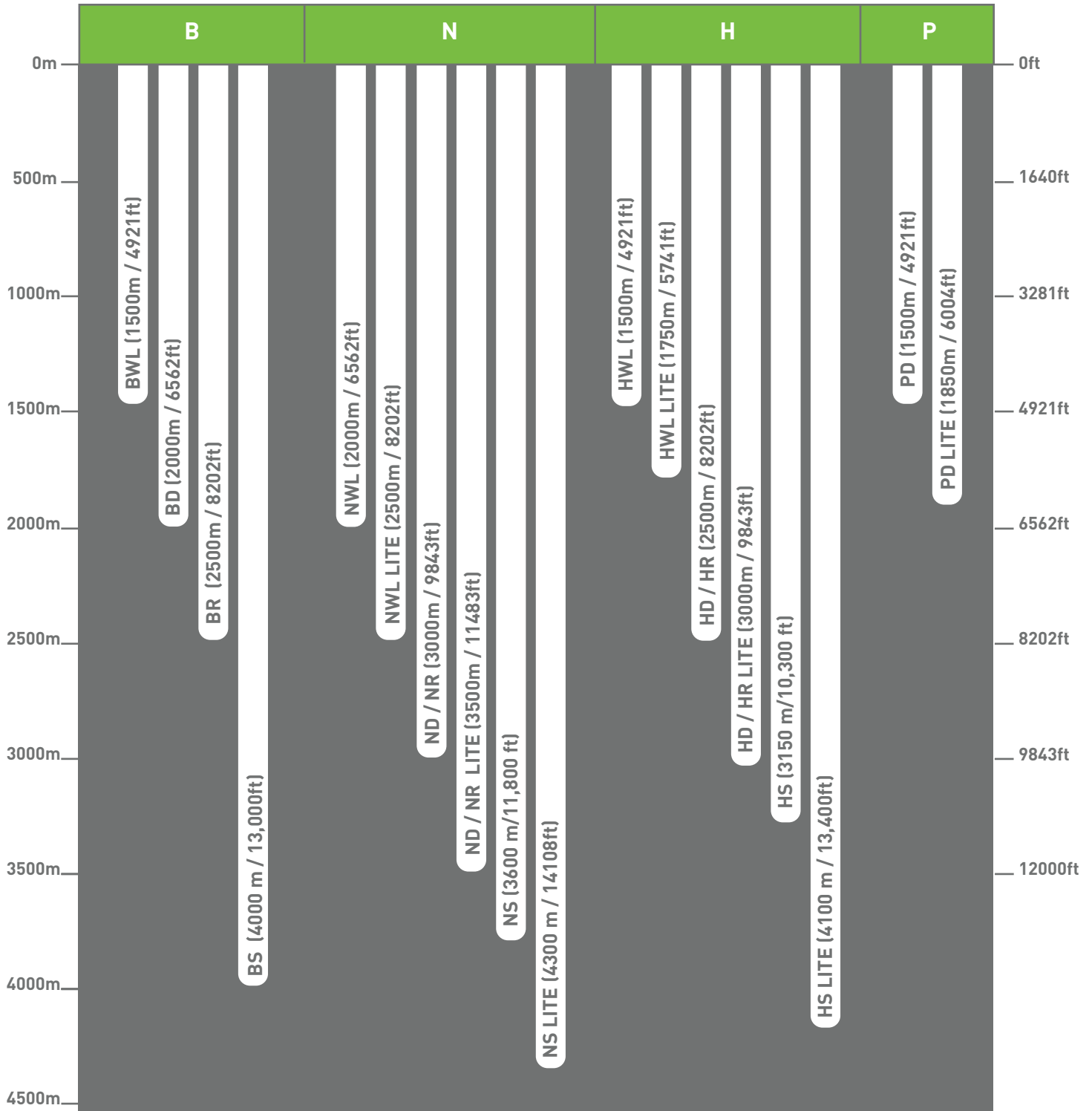

S-MAXX™ WIRELINE DRILL ROD SPECIFICATION

STANDARD S-MAXX DRILL ROD - PARALLEL WALL

Specification (nominal)	Unit	BS	NS	HS
Outer diameter OD	mm (in)	55.58 (2.19)	69.90 (2.75)	88.90 (3.50)
Inner diameter ID	mm (in)	46.1 (1.82)	60.33 (2.38)	77.79 (3.06)
Wall thickness	mm (in)	4.87 (0.19)	4.87 (0.19)	5.59 (0.22)
Pin end length	mm (in)	44.5 (1.75)	44.5 (1.75)	44.5 (1.75)
Thread pitch	mm (in)	10.16 (2.5)	10.16 (2.5)	10.16 (2.5)
Weight	kg/m (lb/ft)	5.97 (4.01)	7.64 (5.14)	11.42 (7.67)
Rod content volume	L/m (g/ft)	1.66 (0.13)	2.86 (0.23)	4.75 (0.38)
Hole volume	L/m (g/ft)	2.83 (0.23)	4.51 (0.36)	7.20 (0.58)
Rod/hole annulus volume	L/m (g/ft)	0.41 (0.03)	0.68 (0.05)	1.06 (0.09)
Recommended max depth	m (ft)	4000 (13,000)	3600 (11,800)	3150 (10,300)
Rated max pullback	kN (lbf)	427 (96,000)	449 (101,000)	534 (120,000)
Rated max drilling torque	Nm (lbf ft)	3661 (2700)	3661 (2700)	4067 (3000)
Min make-up torque to 1000m	Nm (lbf ft)	678 (500)	750.69 (550)	1,017 (750)
Displacement volume	L/m (g/ft)	0.76 (0.06)	0.97 (0.08)	1.45 (0.12)

STANDARD S-MAXX DRILL ROD - LITE

Specification (nominal)	Unit	NS	HS
Outer diameter OD	mm (in)	69.90 (2.75)	88.90 (3.50)
Inner diameter ID - box shoulder	mm (in)	60.33 (2.38)	77.79 (3.06)
Inner diameter ID - midbody	mm (in)	61.82 (2.43)	80.85 (3.18)
Wall thickness - box shoulder	mm (in)	4.76 (0.19)	5.59 (0.22)
Wall thickness - midbody	mm (in)	4.03 (0.16)	4.03 (0.16)
Pin end length	mm (in)	44.5 (1.75)	44.5 (1.75)
Thread pitch	mm (in)	10.16 (2.5)	10.16 (2.5)
Weight*	kg/m (lb/ft)	6.73 (4.53)	9.08 (6.11)
Rod content volume*	L/m (g/ft)	3.03 (0.24)	5.09 (0.41)
Hole volume	L/m (g/ft)	4.51 (0.36)	7.2 (0.58)
Rod/hole annulus volume	L/m (g/ft)	0.68 (0.05)	1.06 (0.09)
Recommended max depth**	m (ft)	4300 (14,000)	4100 (13,400)
Rated max pullback	kN (lbf)	449 (101,000)	534 (120,000)
Rated max drilling torque	Nm (lbf ft)	3661 (2700)	4067 (3,000)
Min make-up torque to 1000m	Nm (lbf ft)	750.69 (550)	1,017 (750)
Displacement volume	L/m (g/ft)	0.88 (0.07)	1.45 (0.12)

* Calculation based on a 10 ft drill rod

** Recommended maximum depth capacity with lower powered drill

These ratings are based on calculated and/or tested values and similar results can be expected. The care and handling, as well as drilling conditions, practices, and equipment will also play a significant role in the ultimate depth capacity and performance. For extreme conditions such as drilling near the limits of depth capacity or holes with frequent wedges/directional changes, pay close attention to rod wear, and replace worn rods with greater frequency (at a reduced wear rate). Ensure make-up torque is increased to match operating torque as depth increases. If additional information is required, please contact your sales representative.

The use of anti-galling thread compound is mandatory for the initial make-up of the joint.

STANDARD WIRELINE DRILL ROD SPECIFICATION

STANDARD WIRELINE DRILL ROD - PARALLEL WALL

Specification (nominal)	Unit	BWL	NWL	HWL
Outer diameter OD	mm (in)	55.58 [2.19]	69.90 [2.75]	88.90 [3.50]
Inner diameter ID	mm (in)	46.10 [1.82]	60.33 [2.38]	77.79 [3.06]
Wall thickness	mm (in)	4.87 [0.19]	4.87 [0.19]	5.59 [0.22]
Pin end length	mm (in)	44.45 [1.75]	44.45 [1.75]	44.45 [1.75]
Thread pitch	mm (in)	8.47 [0.33]	8.47 [0.33]	8.47 [0.33]
Weight	kg/m (lb/ft)	5.97 [4.01]	7.64 [5.14]	11.42 [7.67]
Rod content volume	L/m (g/ft)	1.66 [0.13]	2.86 [0.23]	4.75 [0.38]
Hole volume	L/m (g/ft)	2.83 [0.23]	4.51 [0.36]	7.20 [0.58]
Rod/hole annulus volume	L/m (g/ft)	0.41 [0.03]	0.68 [0.05]	1.06 [0.09]
Recommended max depth	m (ft)	1500.00 [4921.26]	2000.00 [6561.68]	1500.00 [4921.26]
Rated max pullback	kN (lbf)	TBA	222.41 [50,000]	444.82 [100,000]
Rated max drilling torque	Nm (lbf ft)	TBA	1355.82 [1000]	2711.64 [2000]
Min make-up torque to 1000m	Nm (lbf ft)	409.47 [300]	750.69 [550]	1016.85 [750]
Displacement volume	L/m (g/ft)	0.76 [0.06]	0.97 [0.08]	1.45 [0.12]

STANDARD WIRELINE DRILL ROD - LITE

Specification (nominal)	Unit	NWL	HWL
Outer diameter OD	mm (in)	69.90 [2.75]	88.90 [3.50]
Inner diameter ID - box shoulder	mm (in)	60.33 [2.38]	77.79 [3.06]
Inner diameter ID - midbody	mm (in)	61.82 [2.43]	80.85 [3.18]
Wall thickness - box shoulder	mm (in)	4.76 [0.19]	4.76 [0.19]
Wall thickness - midbody	mm (in)	4.03 [0.16]	4.03 [0.16]
Pin end length	mm (in)	44.45 [1.75]	44.45 [1.75]
Thread pitch	mm (in)	8.47 [0.33]	8.47 [0.33]
Weight*	kg/m (lb/ft)	6.73 [4.53]	9.08 [6.11]
Rod content volume*	L/m (g/ft)	3.03 [0.24]	5.09 [0.41]
Hole volume	L/m (g/ft)	4.51 [0.36]	7.20 [0.58]
Rod/hole annulus volume	L/m (g/ft)	0.68 [0.05]	1.06 [0.09]
Recommended max depth**	m (ft)	2500 [8202.10]	1750 [5741.47]
Rated max pullback	kN (lbf)	222.41 [50,000]	444.82 [100,000]
Rated max drilling torque	Nm (lbf ft)	1355.82 [1000]	2711.64 [2000]
Min make-up torque to 1000m	Nm (lbf ft)	750.69 [550]	1016.85 [750]
Displacement volume	L/m (g/ft)	0.88 [0.07]	1.18 [0.10]

* Calculation based on a 10 ft drill rod

** Recommended maximum depth capacity with lower powered drill

These ratings are based on calculated and/or tested values and similar results can be expected. The care and handling, as well as drilling conditions, practices, and equipment will also play a significant role in the ultimate depth capacity and performance. For extreme conditions such as drilling near the limits of depth capacity or holes with frequent wedges/directional changes, pay close attention to rod wear, and replace worn rods with greater frequency (at a reduced wear rate). Ensure make-up torque is increased to match operating torque as depth increases. If additional information is required, please contact your sales representative.

The use of anti-galling thread compound is mandatory for the initial make-up of the joint.

DEEP HOLE WIRELINE DRILL ROD SPECIFICATION

DEEP HOLE WIRELINE DRILL ROD - PARALLEL WALL

Specification (nominal)	Unit	ND		HD		PD	
Outer diameter OD	mm (in)	69.90	(2.75)	88.90	(3.50)	114.30	(4.50)
Inner diameter ID	mm (in)	60.33	(2.38)	77.79	(3.06)	101.60	(4.00)
Wall thickness	mm (in)	4.87	(0.19)	5.59	(0.22)	6.54	(0.26)
Pin end length	mm (in)	44.45	(1.75)	44.45	(1.75)	62.99	(2.48)
Thread pitch	mm (in)	8.47	(0.33)	8.47	(0.33)	10.16	(0.40)
Weight	kg/m (lb/ft)	7.64	(5.14)	11.42	(7.67)	17.41	(11.70)
Rod content volume	L/m (g/ft)	2.86	(0.23)	4.75	(0.38)	8.08	(0.65)
Hole volume	L/m (g/ft)	4.51	(0.36)	7.20	(0.58)	11.82	(0.95)
Rod/hole annulus volume	L/m (g/ft)	0.68	(0.05)	1.06	(0.09)	1.53	(0.12)
Recommended max depth	m (ft)	3000	(9842.52)	2500	(8202.10)	TBA	
Rated max pullback	kN (lbf)	333.62	(75,000)	511.55	(115000)	TBA	
Rated max drilling torque	Nm (lbf ft)	2237	(1650)	4745.30	(3500)	TBA	
Min make-up torque to 1000m	Nm (lbf ft)	750.69	(550)	1016.85	(750)	1016.85	(750)
Displacement volume	L/m (g/ft)	0.97	(0.08)	1.45	(0.12)	2.22	(0.18)

DEEP HOLE WIRELINE DRILL ROD - LITE

Specification (nominal)	Unit	ND LITE		HD LITE		PD LITE	
Outer diameter OD	mm (in)	69.90	(2.75)	88.90	(3.50)	114.30	(4.50)
Inner diameter ID - box shoulder	mm (in)	60.33	(2.38)	77.79	(3.06)	101.60	(4.00)
Inner diameter ID - midbody	mm (in)	61.82	(2.43)	80.85	(3.18)	106.30	(4.19)
Wall thickness - box shoulder	mm (in)	4.76	(0.19)	4.76	(0.19)	5.56	(0.22)
Wall thickness - midbody	mm (in)	4.03	(0.16)	4.03	(0.16)	4.03	(0.16)
Pin end length	mm (in)	44.45	(1.75)	44.45	(1.75)	62.99	(2.48)
Thread pitch	mm (in)	8.47	(0.33)	8.47	(0.33)	10.16	(0.40)
Weight*	kg/m (lb/ft)	6.73	(4.53)	9.08	(6.11)	12.44	(8.37)
Rod content volume*	L/m (g/ft)	3.03	(0.24)	5.09	(0.41)	8.84	(0.71)
Hole volume	L/m (g/ft)	4.51	(0.36)	7.20	(0.58)	11.82	(0.95)
Rod/hole annulus volume	L/m (g/ft)	0.68	(0.05)	1.06	(0.09)	1.53	(0.12)
Recommended max depth**	m (ft)	3500	(11482.94)	3000	(9842.52)	TBA	
Rated max pullback	kN (lbf)	333.62	(75,000)	511.55	(115000)	TBA	
Rated max drilling torque	Nm (lbf ft)	2237	(1650)	4745.30	(3500)	TBA	
Min make-up torque to 1000m	Nm (lbf ft)	750.69	(550)	1016.85	(750)	1016.85	(750)
Displacement volume	L/m (g/ft)	0.88	(0.07)	1.18	(0.10)	1.61	(0.13)

* Calculation based on a 10 ft drill rod

** Recommended maximum depth capacity with lower powered drill

These ratings are based on calculated and/or tested values and similar results can be expected. The care and handling, as well as drilling conditions, practices, and equipment will also play a significant role in the ultimate depth capacity and performance. For extreme conditions such as drilling near the limits of depth capacity or holes with frequent wedges/directional changes, pay close attention to rod wear, and replace worn rods with greater frequency (at a reduced wear rate). Ensure make-up torque is increased to match operating torque as depth increases. If additional information is required, please contact your sales representative.

The use of anti-galling thread compound is mandatory for the initial make-up of the joint.

REVERSE FLANK WIRELINE DRILL ROD SPECIFICATION

REVERSE FLANK WIRELINE DRILL ROD - PARALLEL WALL

Specification (nominal)	Unit	BR	NR	HR
Outer diameter OD	mm (in)	55.58 (2.19)	69.90 (2.75)	88.90 (3.50)
Inner diameter ID	mm (in)	46.10 (1.82)	60.33 (2.38)	77.79 (3.06)
Wall thickness	mm (in)	4.87 (0.19)	4.87 (0.19)	5.59 (0.22)
Pin end length	mm (in)	41.91 (1.65)	41.91 (1.65)	41.91 (1.75)
Thread pitch	mm (in)	8.47 (0.33)	8.47 (0.33)	8.47 (0.33)
Weight	kg/m (lb/ft)	5.97 (4.01)	7.64 (5.14)	11.42 (7.67)
Rod content volume	L/m (g/ft)	1.66 (0.13)	2.86 (0.23)	4.75 (0.38)
Hole volume	L/m (g/ft)	2.83 (0.23)	4.51 (0.36)	7.20 (0.58)
Rod/hole annulus volume	L/m (g/ft)	0.41 (0.03)	0.68 (0.05)	1.06 (0.09)
Recommended max depth	m (ft)	>2500 (8205)	>3000 (9842)	>2500 (8202.10)
Rated max pullback	kN (lbf)	311.38 (70,000)	378.10 (85,000)	511.55 (115000)
Rated max drilling torque	Nm (lbf ft)	2711.64 (2,000)	2373 (1750)	3525.13 (2600)
Min make-up torque to 1000m	Nm (lbf ft)	409.47 (300)	750.69 (550)	1016.85 (750)
Displacement volume	L/m (g/ft)	0.76 (0.06)	0.97 (0.08)	1.45 (0.12)

REVERSE FLANK WIRELINE DRILL ROD - LITE

Specification (nominal)	Unit	NR LITE	HR LITE
Outer diameter OD	mm (in)	69.90 (2.75)	88.90 (3.50)
Inner diameter ID - box shoulder	mm (in)	60.33 (2.38)	77.79 (3.06)
Inner diameter ID - midbody	mm (in)	61.82 (2.43)	80.85 (3.18)
Wall thickness - box shoulder	mm (in)	4.76 (0.19)	4.76 (0.19)
Wall thickness - midbody	mm (in)	4.03 (0.16)	4.03 (0.16)
Pin end length	mm (in)	41.91 (1.65)	44.45 (1.75)
Thread pitch	mm (in)	8.47 (0.33)	8.47 (0.33)
Weight*	kg/m (lb/ft)	6.73 (4.53)	9.08 (6.11)
Rod content volume*	L/m (g/ft)	3.03 (0.24)	5.09 (0.41)
Hole volume	L/m (g/ft)	4.51 (0.36)	7.20 (0.58)
Rod/hole annulus volume	L/m (g/ft)	0.68 (0.05)	1.06 (0.09)
Recommended max depth**	m (ft)	>3500 (11,482)	>3000 (9842.52)
Rated max pullback	kN (lbf)	378.10 (85,000)	511.55 (115000)
Rated max drilling torque	Nm (lbf ft)	2373 (1750)	3525.13 (2600)
Min make-up torque to 1000m	Nm (lbf ft)	750.69 (550)	1016.85 (750)
Displacement volume	L/m (g/ft)	0.88 (0.07)	1.18 (0.10)

* Calculation based on a 10 ft drill rod

** Recommended maximum depth capacity with lower powered drill

These ratings are based on calculated and/or tested values and similar results can be expected. The care and handling, as well as drilling conditions, practices, and equipment will also play a significant role in the ultimate depth capacity and performance. For extreme conditions such as drilling near the limits of depth capacity or holes with frequent wedges/directional changes, pay close attention to rod wear, and replace worn rods with greater frequency (at a reduced wear rate). Ensure make-up torque is increased to match operating torque as depth increases. If additional information is required, please contact your sales representative.

The use of anti-galling thread compound is mandatory for the initial make-up of the joint.

END-TO END DRILLING SOLUTIONS

We offer a complete line of adapter subs and locking couplings precision-machined to fit all Drillers Edge drill rods.

As a leading supplier of innovative drilling solutions, Di-Corp has the products and supplies you need to ensure maximum productivity for your drilling operations. We've been sourcing the best and building it better since 1960 and have the knowledge and expertise to stand behind what we sell.

Di-Corp is your one-stop source for all of the following drilling consumables, backed by decades of drilling experience, fluids engineering, and customer-focused 24/7 service:

- Drillers Edge™ Wireline Coring Rods, Casing, and Adapter Subs
- CoreMatrix™ Bits, Edge Reaming Shells™, and Diamond Tools
- Core Retrieval Tools and Accessories
- EarthPro™ Drilling Fluids, Greases, and Additives
- Tooling, Consumables, and Accessories





DI-CORP

DOWN TO EARTH BUSINESS

1.800.661.2792 | www.di-corp.com | info@di-corp.com
Di-Corp is a registered trade name of Diversity Technologies Corp.